

Lieferumfang / Anwendung
Included / Technical Specifications

Montage /
Fitting

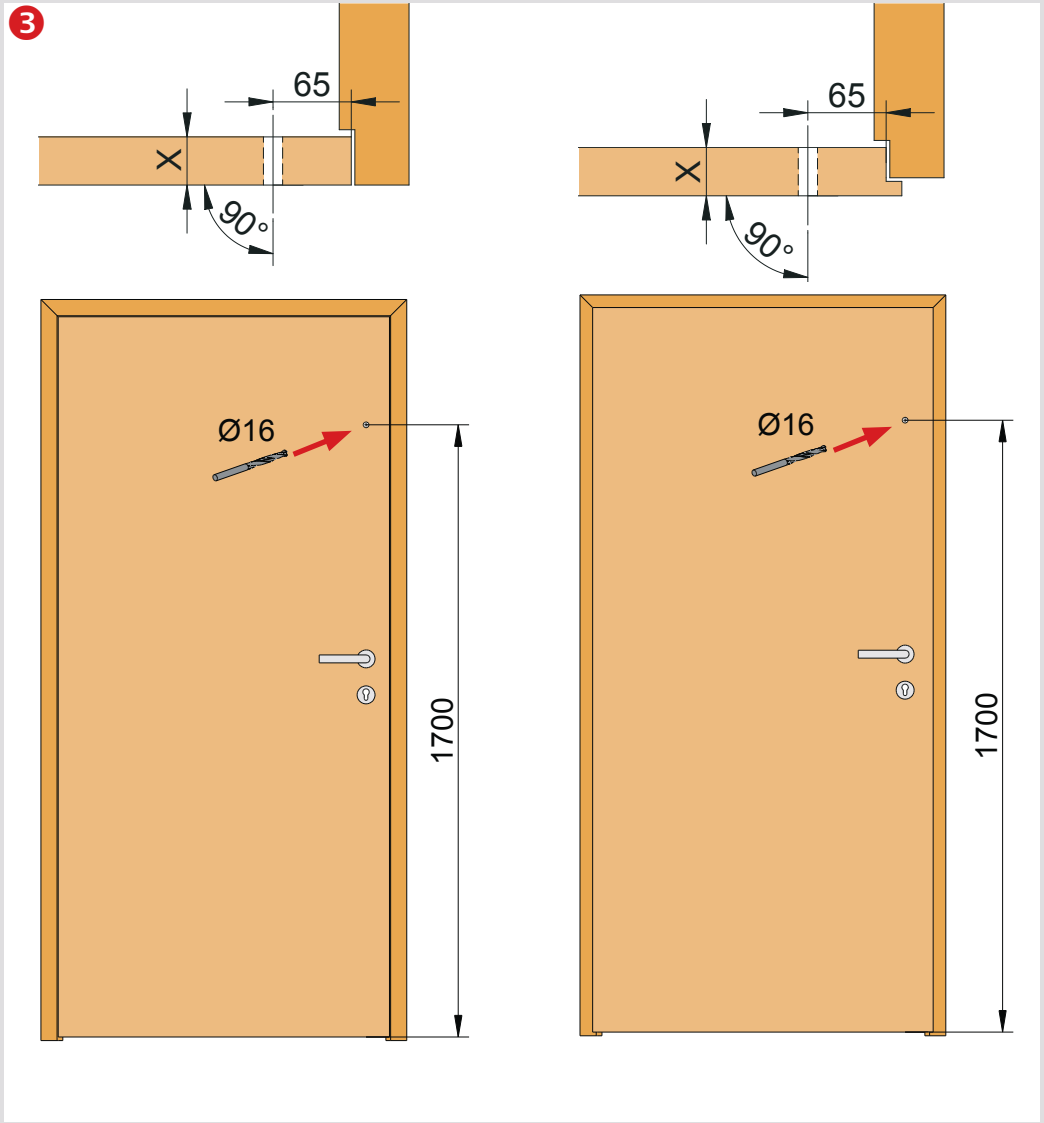
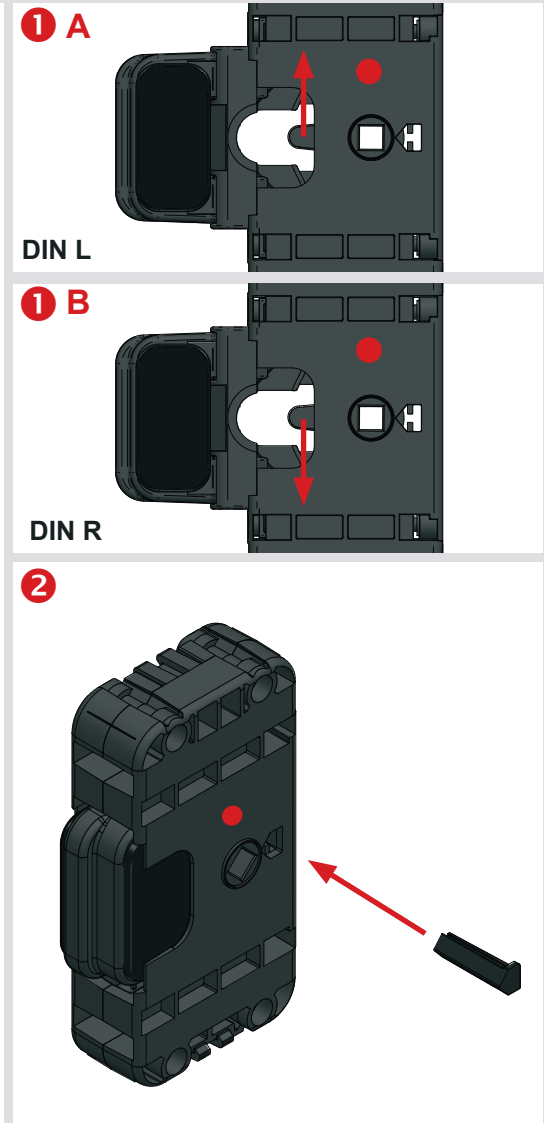
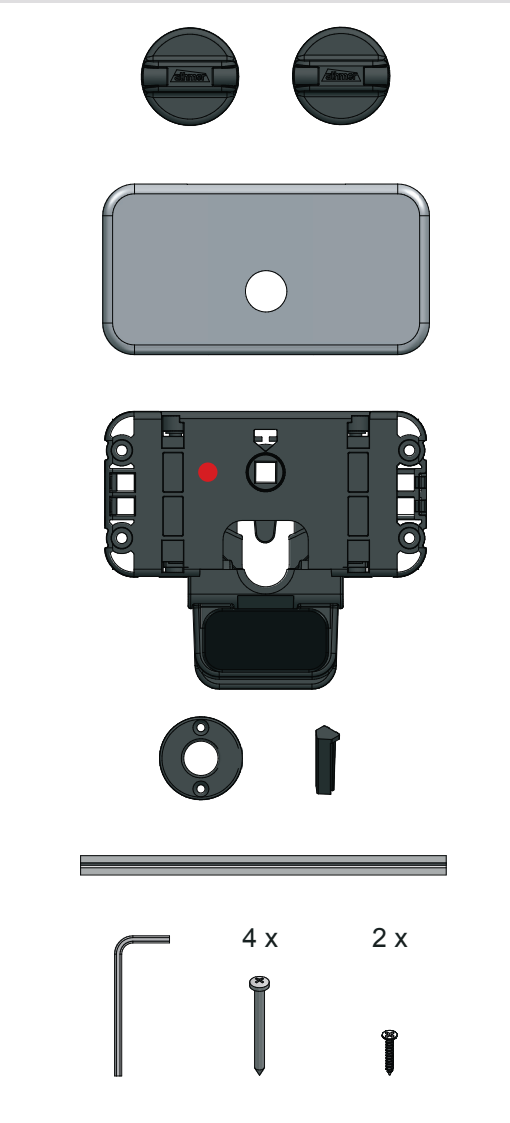

Bitte beachten Sie die alternativen Einbausituationen in den Anwendungsbeispielen. Der Einsatz von Fingerschutz entbindet nicht von der Aufsichtspflicht. Technische Änderungen vorbehalten.
 Please note the alternative installation situations in the application examples. The use of finger protection does not obviate the duty of supervision. Technical specifications are subject to change.

Montage / Fitting

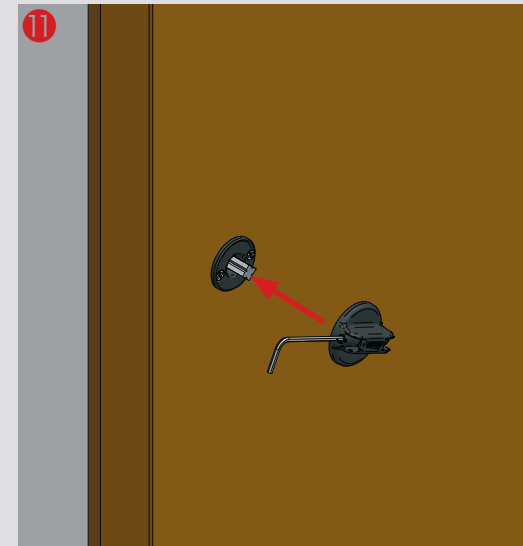
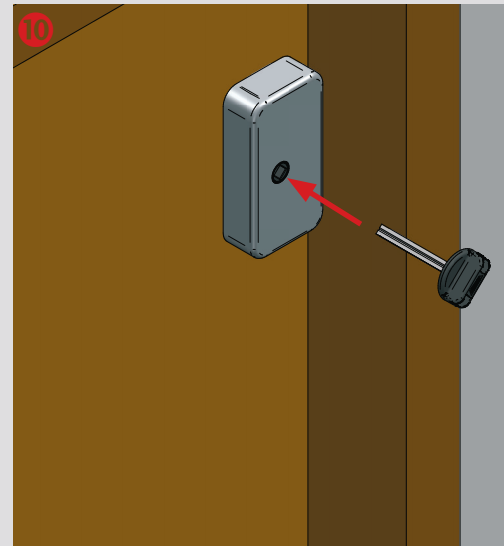
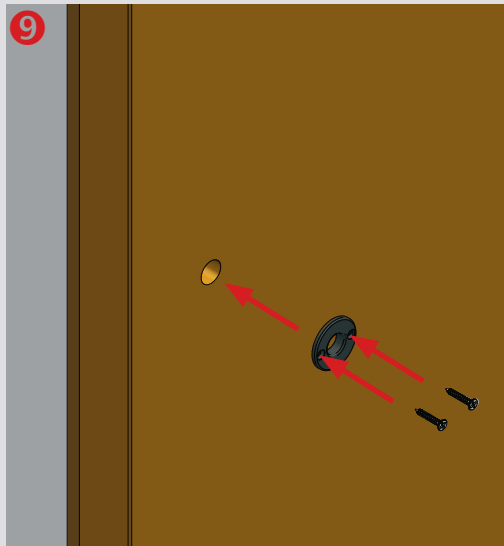
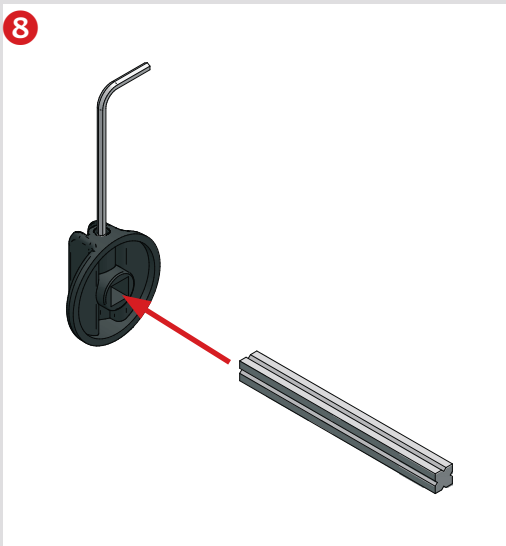
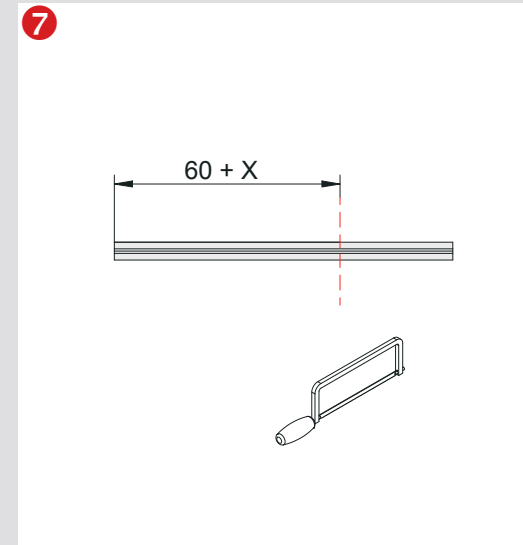
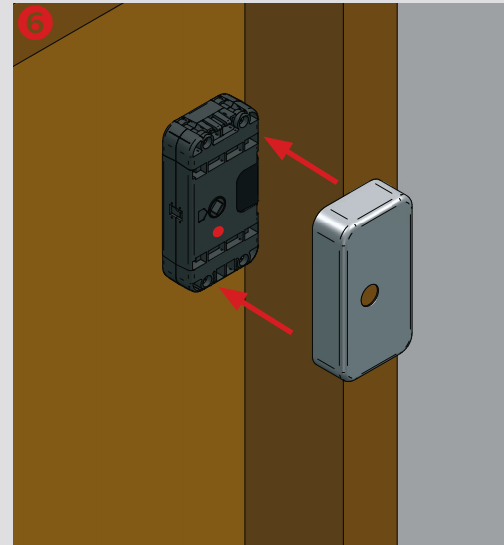
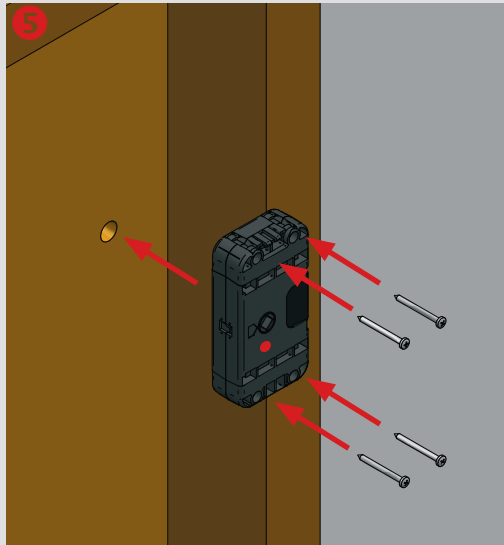
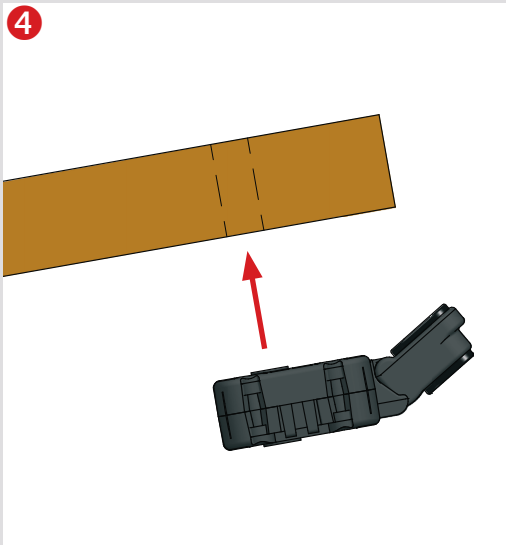

Bitte beachten Sie die alternativen Einbausituationen in den Anwendungsbeispielen. Der Einsatz von Fingerschutz entbindet nicht von der Aufsichtspflicht. Technische Änderungen vorbehalten.
Please note the alternative installation situations in the application examples. The use of finger protection does not obviate the duty of supervision. Technical specifications are subject to change.